

HMC7044

REVISIONS			
REV	DESCRIPTION	DATE	APPROVED

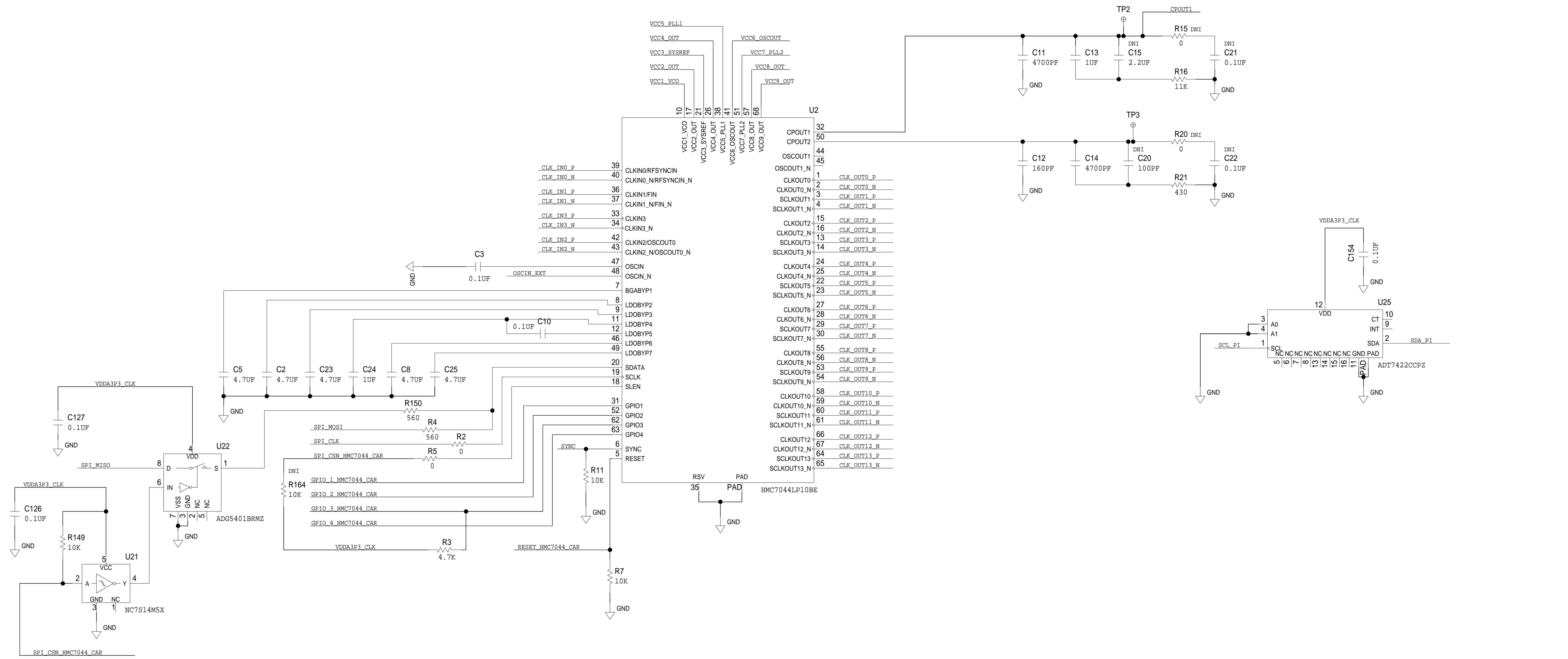

	SCHEMATIC		
	HW TYPE : Customer Evaluation Z Product(s) : HMC7044 : ADP2386		
	DESIGN VIEW <DESIGN_VIEW>	DRAWING NO. 02_064652	REV B
	PTD ENGINEER C. CARBUNARU	SIZE D	SCALE 1:1
		SHEET 2 OF 9	

REVISIONS			
REV	DESCRIPTION	DATE	APPROVED

TCXO - VCXO

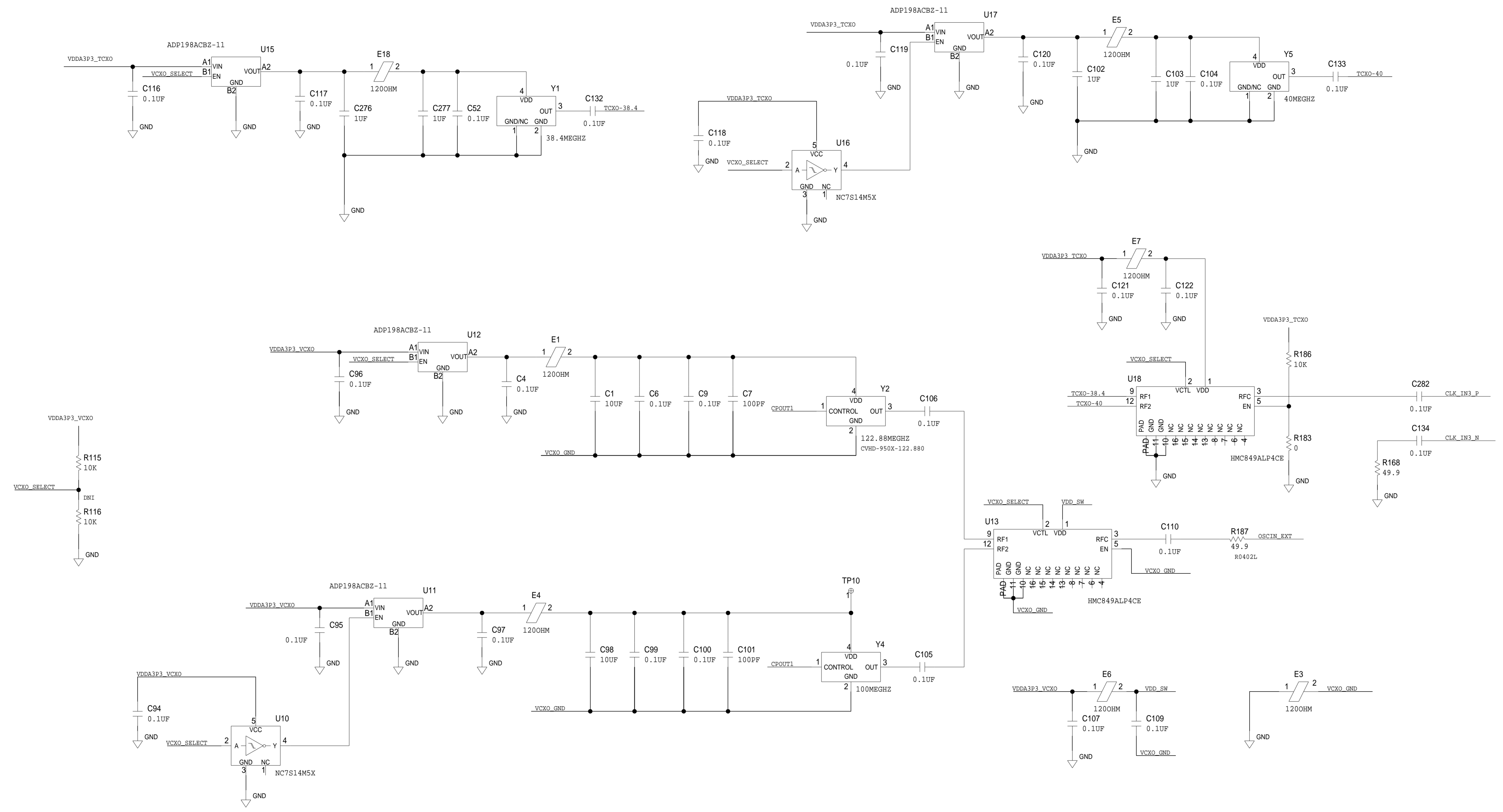

	SCHEMATIC		
	HW TYPE : Customer Evaluation Z Product(s) : HMC7044 : ADP2386		
DESIGN VIEW <DESIGN_VIEW>	DRAWING NO. 02_064652	REV B	
PTD ENGINEER C. CARBUNARU	SIZE D	SCALE 1:1	SHEET 3 OF 9

REVISIONS			
REV	DESCRIPTION	DATE	APPROVED

HMC DECOUPLING

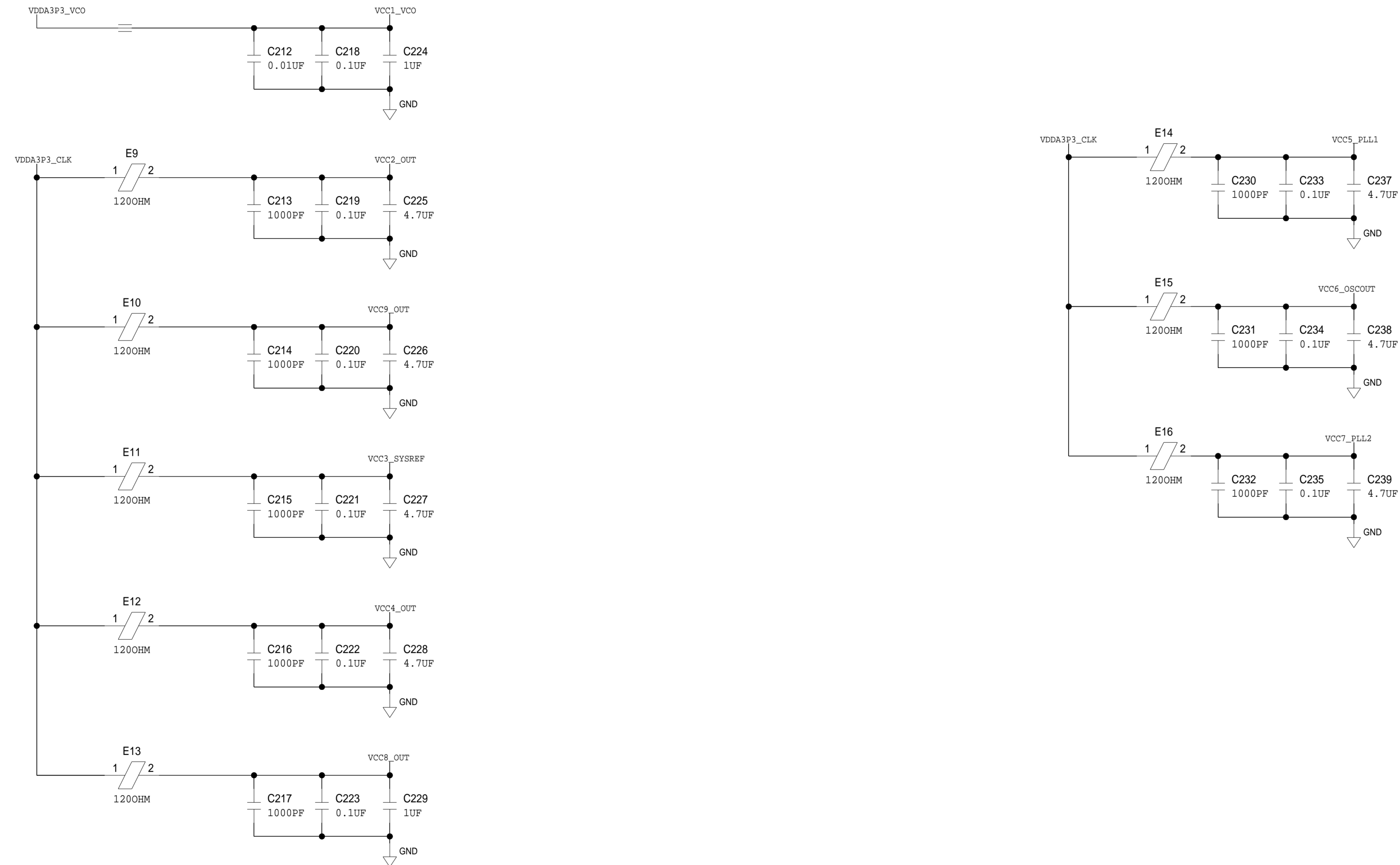

	SCHEMATIC		
	HW TYPE : Customer Evaluation Z Product(s) : HMC7044 : ADP2386		
	DESIGN VIEW <DESIGN_VIEW>	DRAWING NO. 02_064652	REV B
	PTD ENGINEER C. CARBUNARU	SIZE D	SCALE 1:1
SHEET 4		OF 9	

POWER SUPPLIES

REVISIONS			
REV	DESCRIPTION	DATE	APPROVED

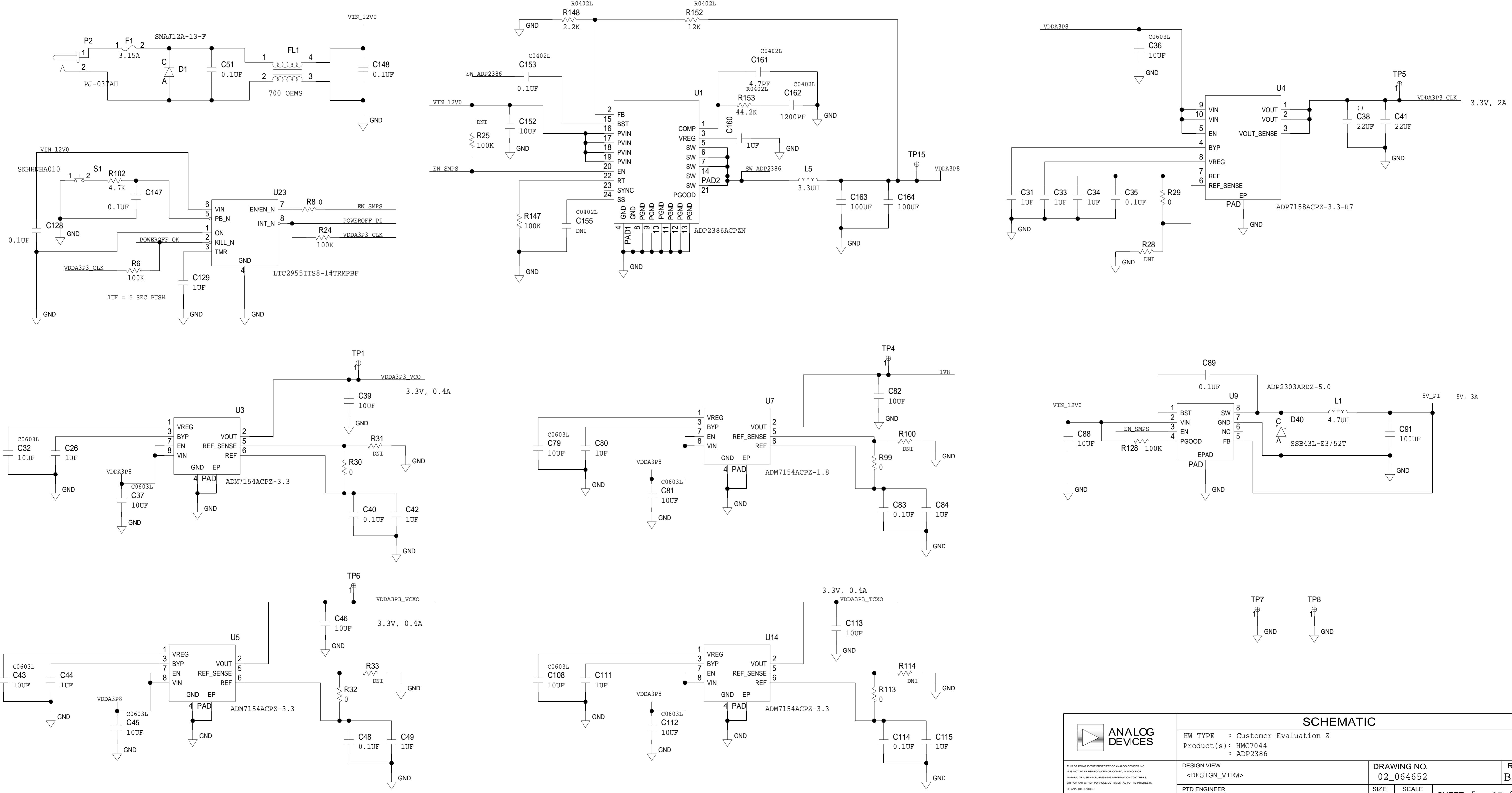

	SCHEMATIC		
	HW TYPE : Customer Evaluation Z Product(s) : HMC7044 : ADP2386		
	DESIGN VIEW <DESIGN_VIEW>	DRAWING NO. 02_064652	REV B
	PTD ENGINEER C. CARBUNARU	SIZE D	SCALE 1:1
		SHEET 5 OF 9	

AD9545

REVISIONS			
REV	DESCRIPTION	DATE	APPROVED

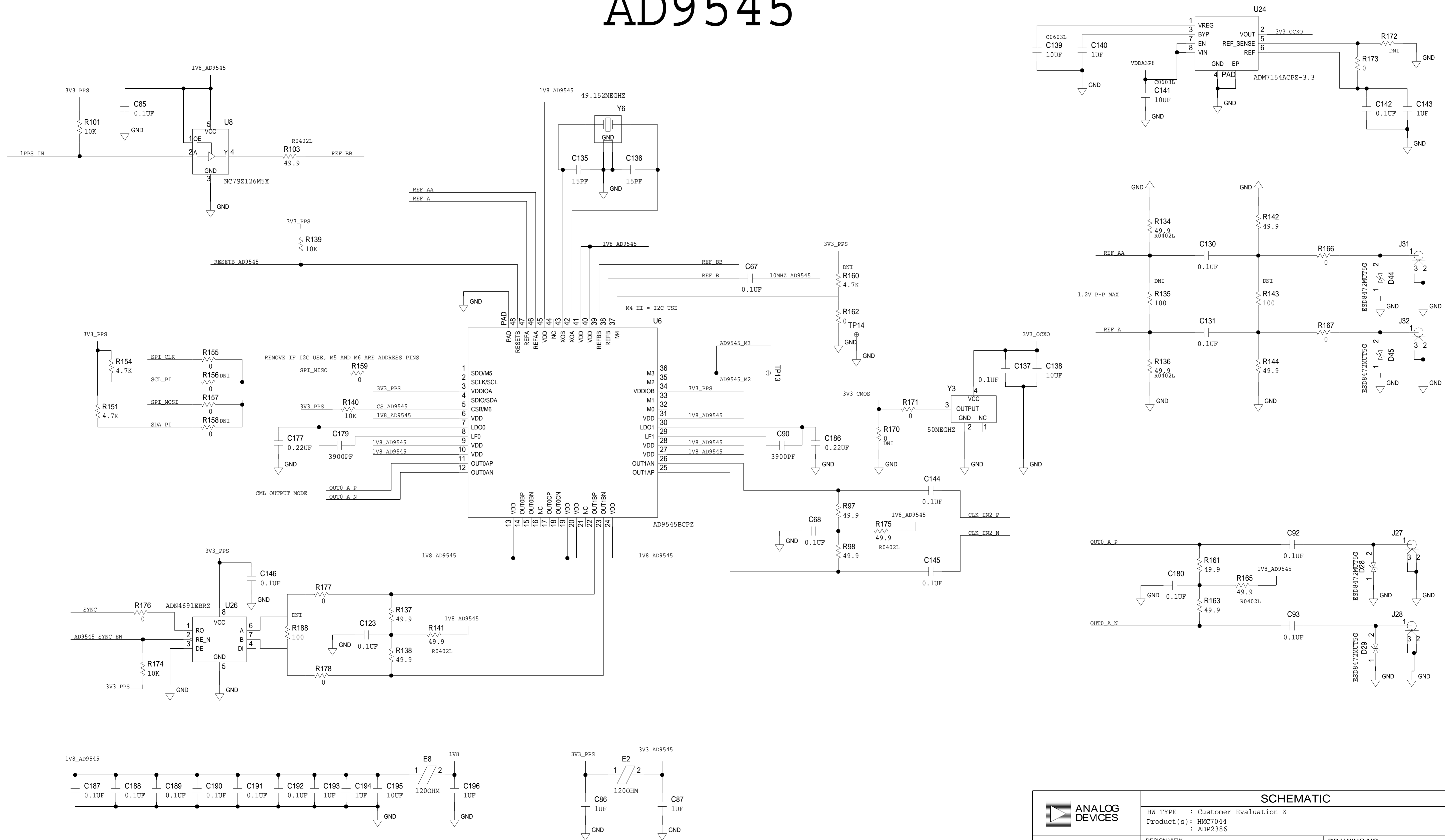

	SCHEMATIC		
	HW TYPE : Customer Evaluation Z Product(s) : HMC7044 : ADP2386		
	DESIGN VIEW <DESIGN_VIEW>	DRAWING NO. 02_064652	REV B
	PTD ENGINEER C. CARBUNARU	SIZE D SCALE 1:1	SHEET 6 OF 9

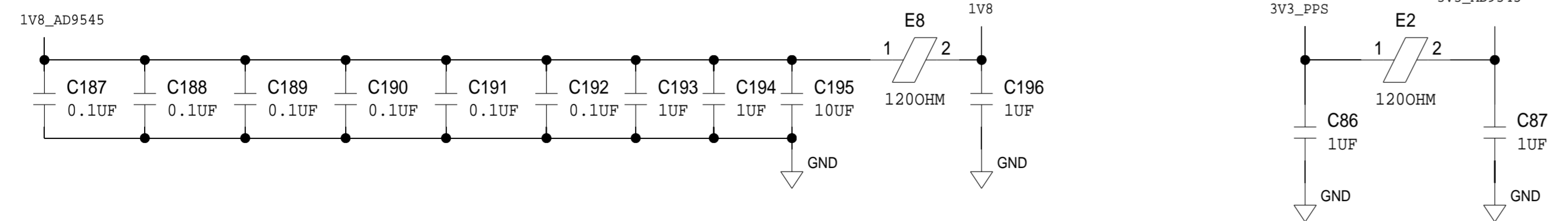

RF CONNECTORS

REVISIONS			
REV	DESCRIPTION	DATE	APPROVED

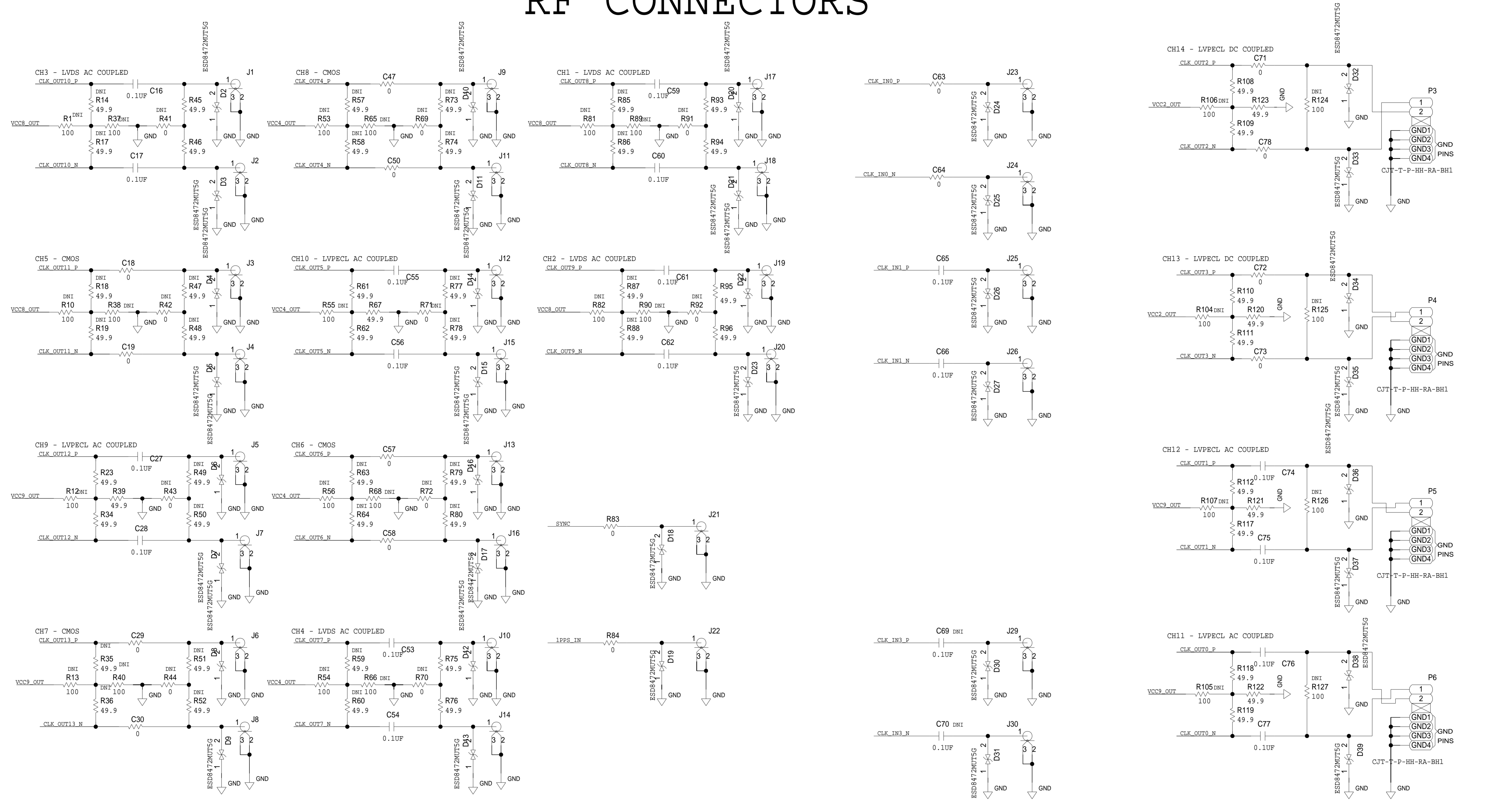

SCHEMATIC			
		HW TYPE : Customer Evaluation Z Product(s) : HMC7044 : ADP2386	
DESIGN VIEW <DESIGN_VIEW>	DRAWING NO. 02_064652	REV B	
PTD ENGINEER C. CARBUNARU	SIZE D	SCALE 1:1	SHEET 7 OF 9

THIS DRAWING IS THE PROPERTY OF ANALOG DEVICES INC. IT IS NOT TO BE REPRODUCED OR COPIED, IN WHOLE OR IN PART, OR USED IN ANY MANNER THAT IS DESTRUCTIVE TO THE INTERESTS OF ANALOG DEVICES. THE EQUIPMENT SHOWN HEREIN MAY BE PROTECTED BY PATENTS OWNED OR CONTROLLED BY ANALOG DEVICES.

REVISIONS			
REV	DESCRIPTION	DATE	APPROVED

10MHZ REF

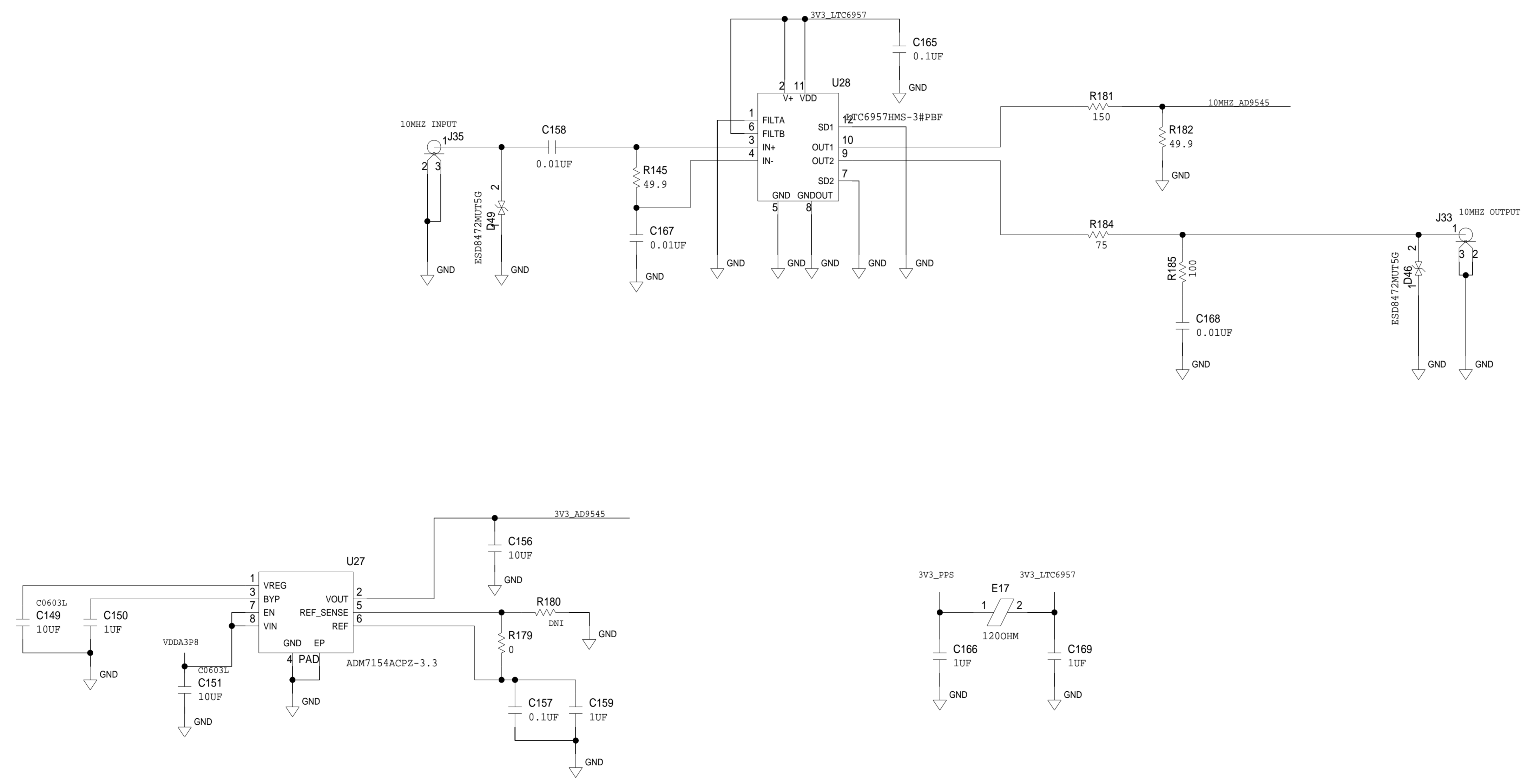

	SCHEMATIC		
	HW TYPE : Customer Evaluation Z Product(s) : HMC7044 : ADP2386		
	DESIGN VIEW <DESIGN_VIEW>	DRAWING NO. 02_064652	REV B
	PTD ENGINEER C. CARBUNARU	SIZE D	SCALE 1:1
SHEET 8 OF 9			

REVISIONS			
REV	DESCRIPTION	DATE	APPROVED

CONNECTORS

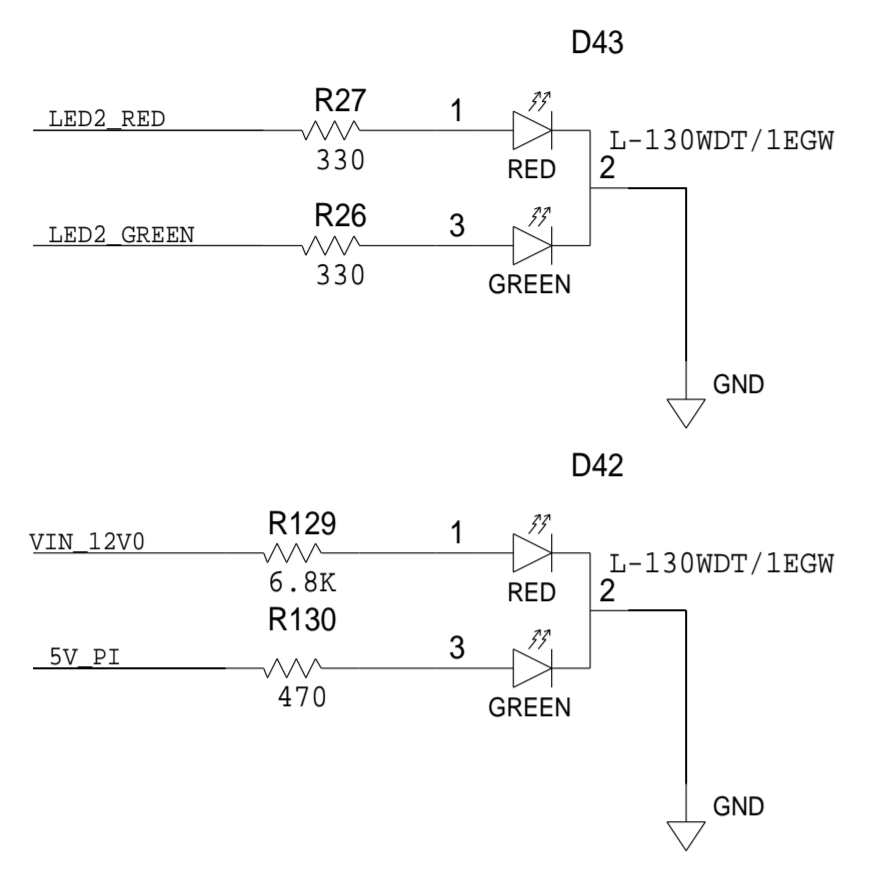

EXT DIGITAL INTERFACE CONNECTOR

CONNECT VCXO_SELECT TO GND TO USE 100MHZ VCXO
 CONNECT EXT_SELECT TO GND TO USE EXT INTERFACE

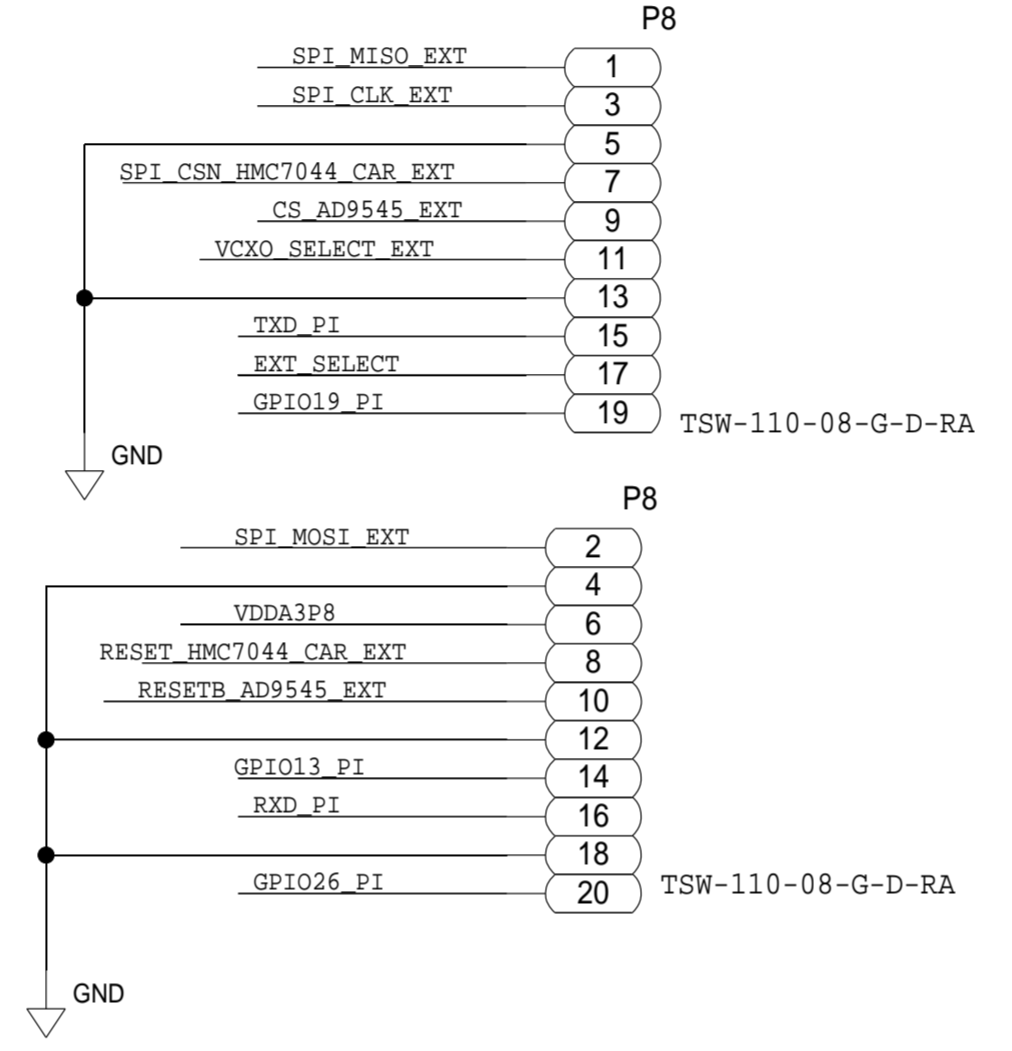

CONNECT GPIO13_PI TO GND TO SET RASPBERRY PI AS WIRELESS ACCESS POINT

RASPBERRY PI CONNECTOR

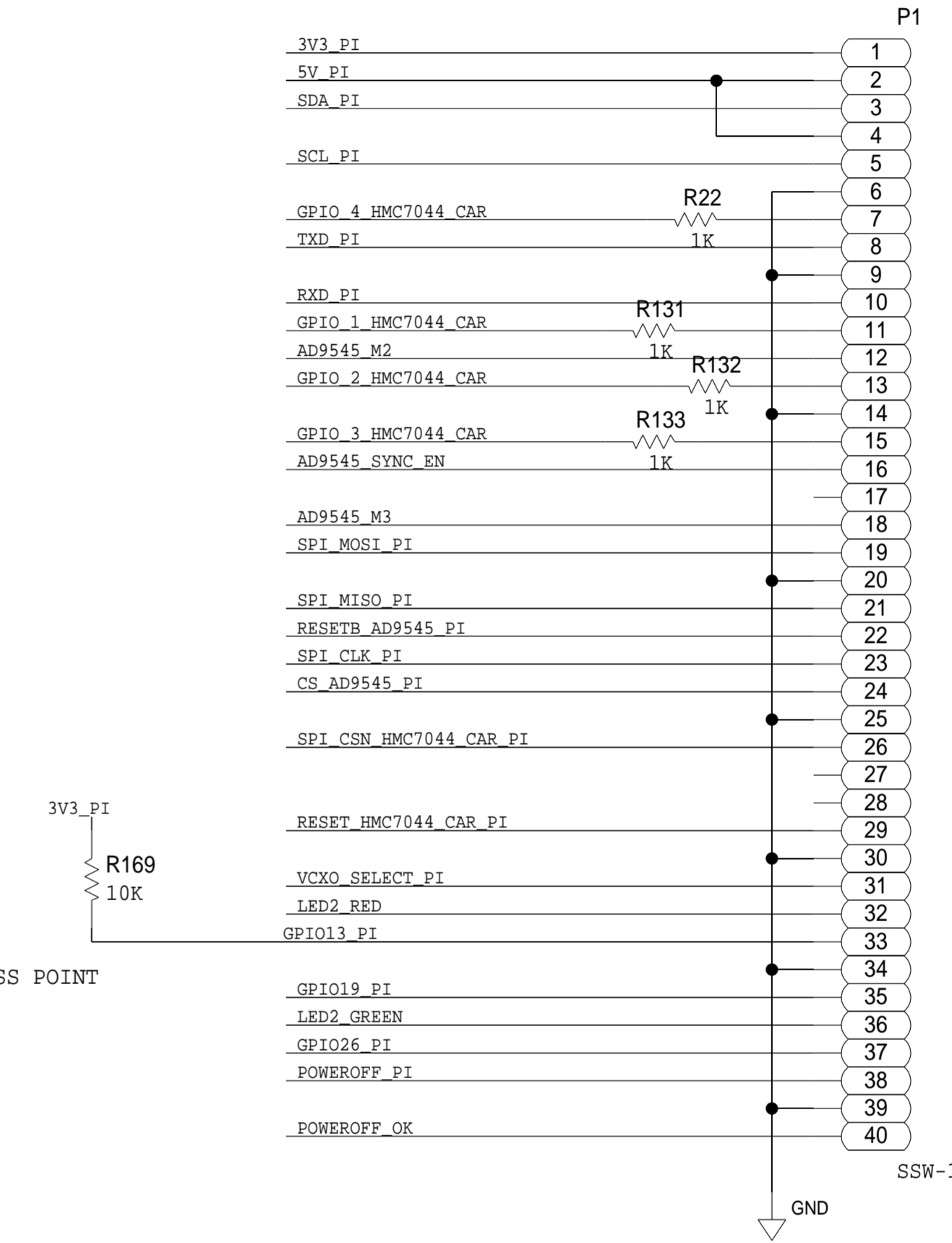

GPIO13 = 0, RASPBERRY PI AS WIRELESS ACCESS POINT

FAN CONNECTOR

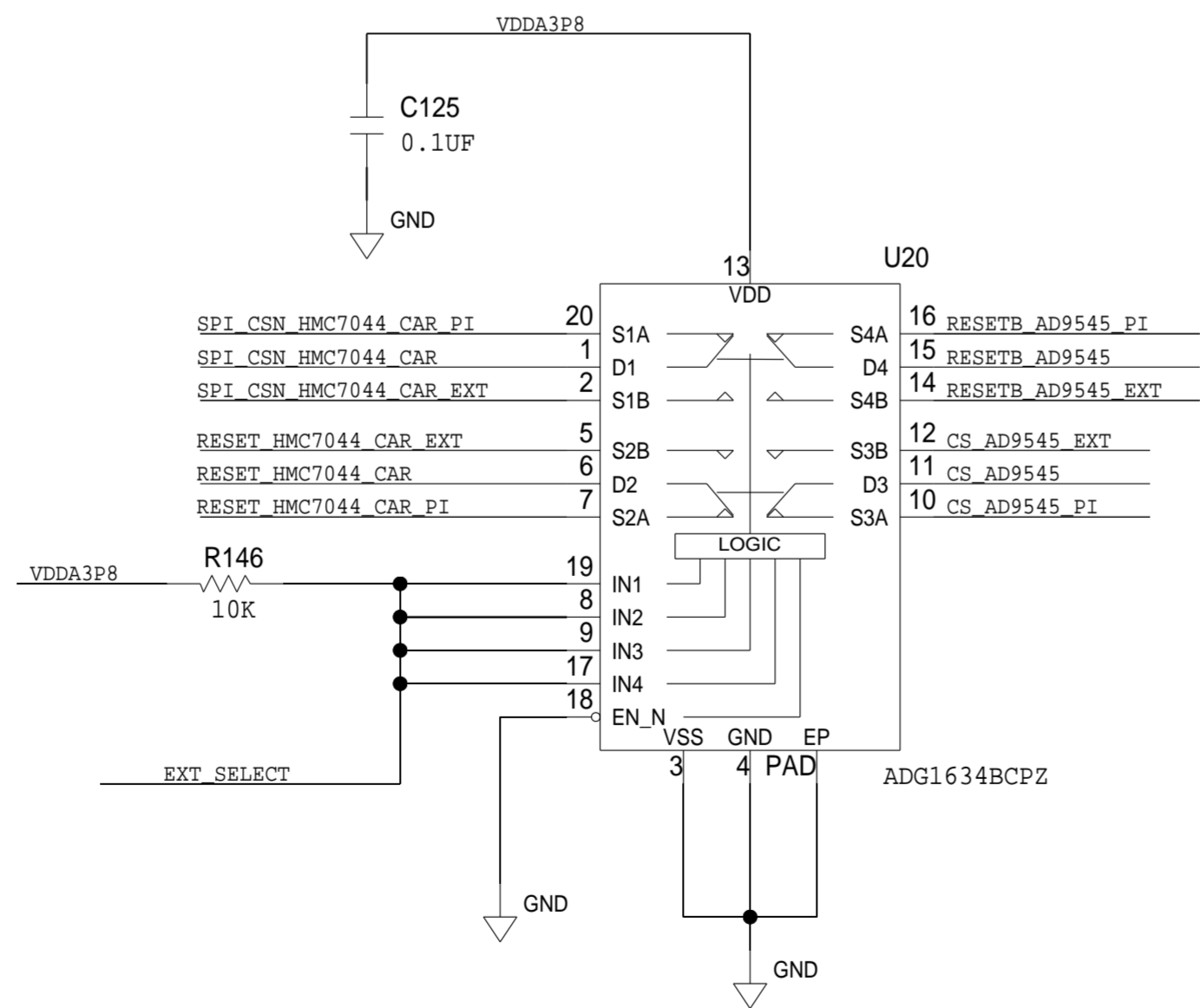
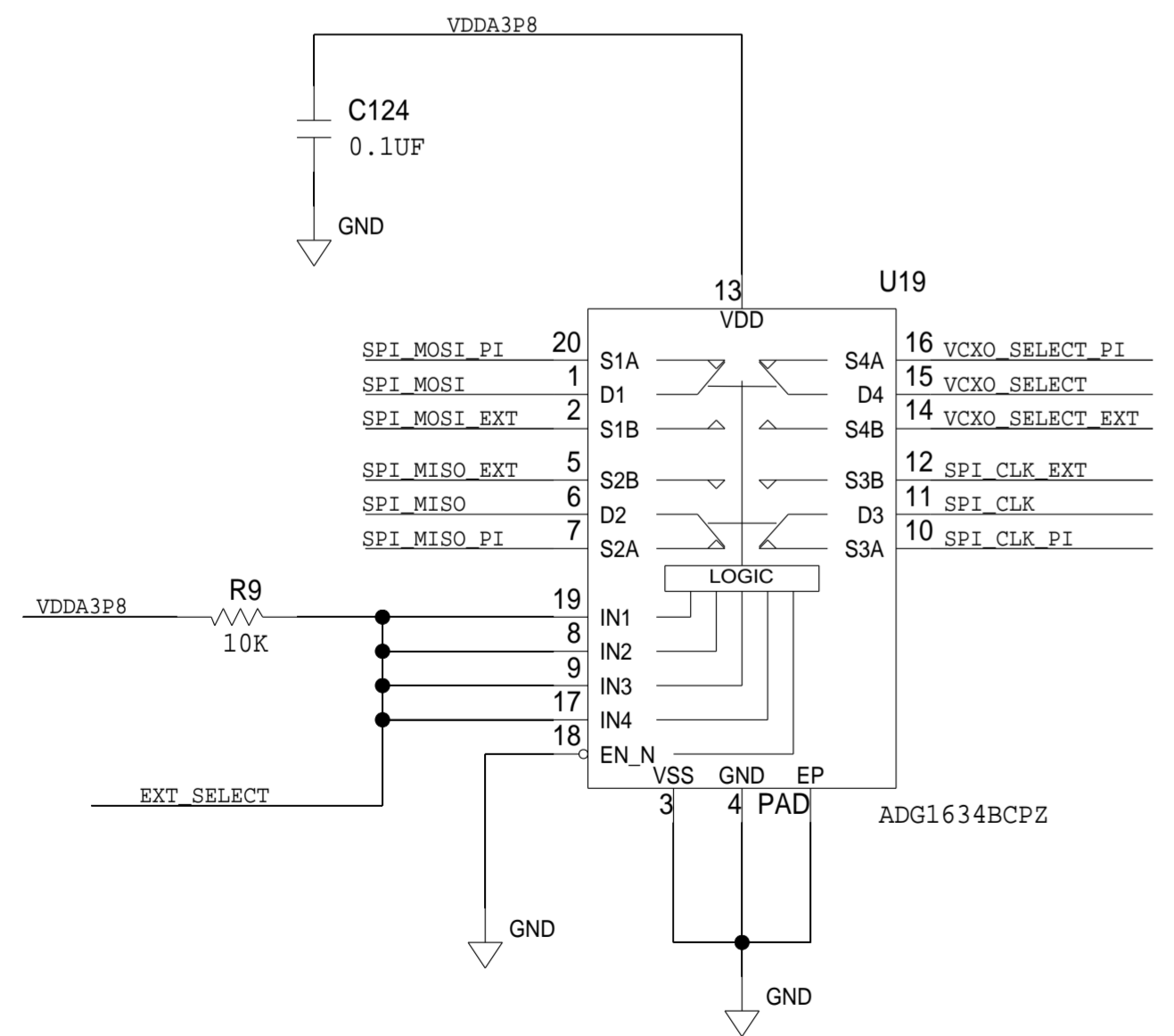
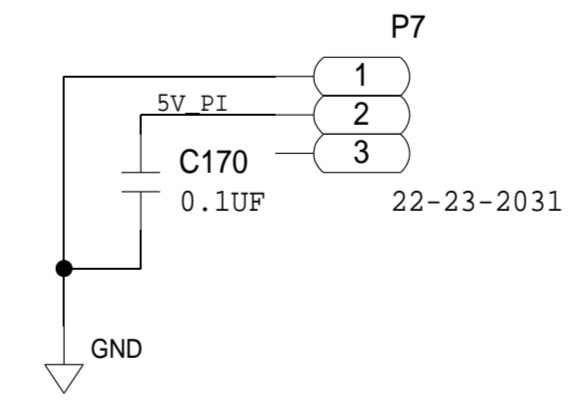

SCHEMATIC			
		HW TYPE : Customer Evaluation Z Product(s): HMC7044 : ADP2386	
DESIGN VIEW <DESIGN_VIEW>		DRAWING NO. 02_064652	
PTD ENGINEER C. CARBUNARU		SIZE D	SCALE 1:1
		SHEET 9	OF 9
		REV B	

THIS DRAWING IS THE PROPERTY OF ANALOG DEVICES INC. IT IS NOT TO BE REPRODUCED OR COPIED, IN WHOLE OR IN PART, OR USED IN ANY MANNER WITHOUT THE WRITTEN PERMISSION OF ANALOG DEVICES. THE EQUIPMENT SHOWN HEREON MAY BE PROTECTED BY PATENTS OWNED OR CONTROLLED BY ANALOG DEVICES.